



TSDZ2 中置电机系统

TSDZ2 Central Motor Drive System

Install Manual



装

配

手

册

中置电机装配流程

Motor Installation Process

1 电机安装

第一步：电机中轴套依箭头方向推入自行车五通管，长度为 68mm 的五通管，则中轴套露出长度为 11mm，如图 1。

Step 1. Push Motor BB axle inside BB tube(68mm) as per picture below, the exposed axle length on the left side is 11mm as Pic 1

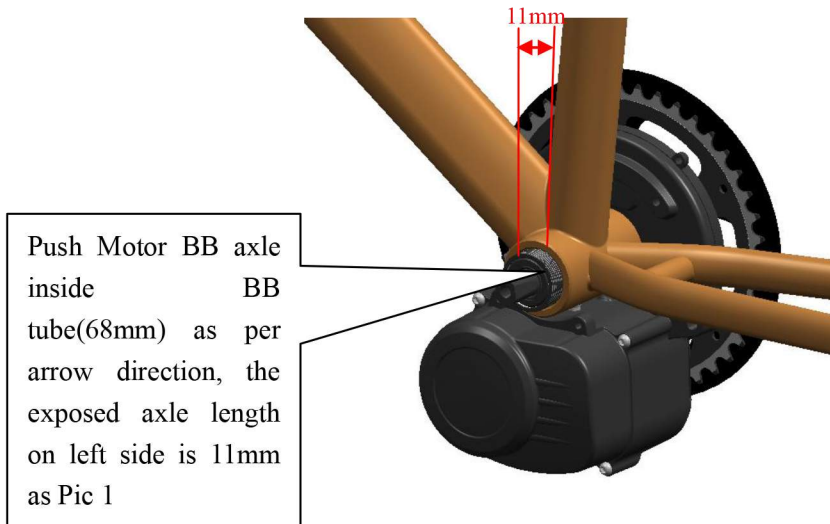

Pic1

第二步：安装加强板。如图 2

Step 2. Install Securing plate. Please refer to Pic2.

1、将加强板套在中轴五通上

1. Put securing plate onto BB axle.

2、两个铝垫圈放在加强板与中置电机之间

2. Put 2 washers between motor and securing plate.

3、用两个 M5×16 的内六角螺钉将加强板与中置电机锁紧

3. Tighten the securing plate and the motor with two M5×16 screws.

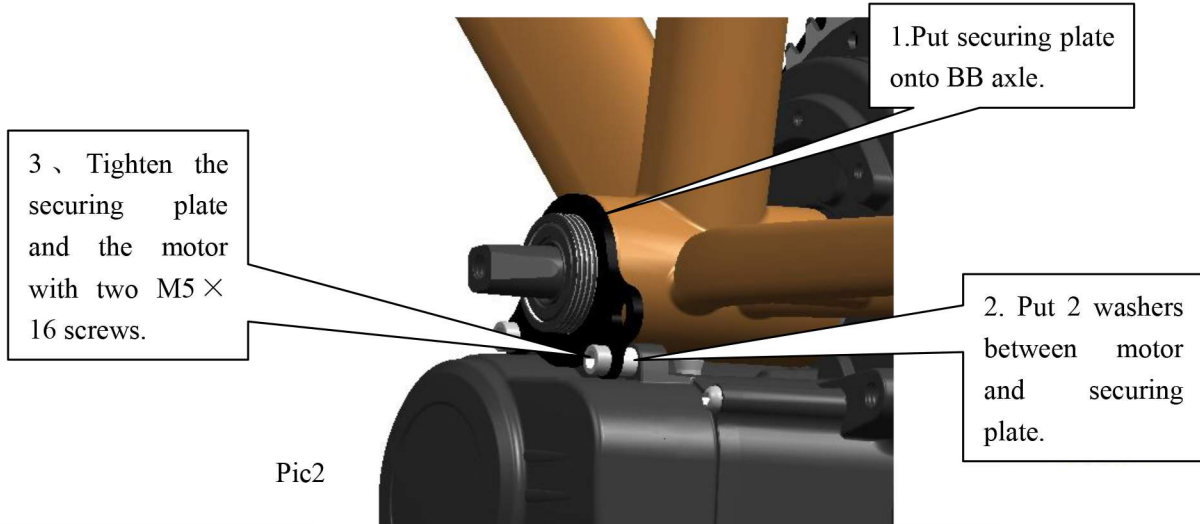

Pic2

第三步：将 M33.5 螺母旋到中轴套上，用专用工具拧紧，锁紧力为 $40\text{N} \cdot \text{m}$ 。如图 3
 Step 3. Screw the M33.5 nut onto the BB axle, using an affiliated wrench by $40\text{N} \cdot \text{m}$ torque.
 Please refer to Pic3.

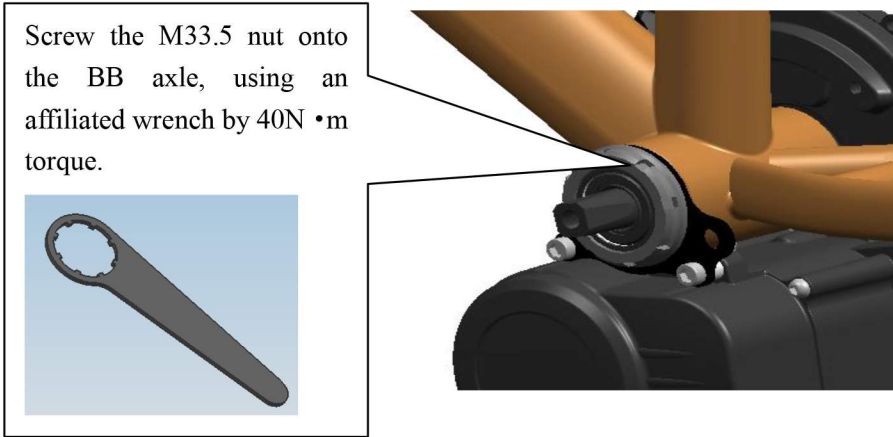

Pic3

第四步：固定电机与车架。如图 4.

Step 4. Fix the main body of the Motor onto bike-Frame. Please refer to Pic4.

- 1、M8*40 的螺钉连接固定块和中置电机主体螺柱孔，预紧。
1. Install the fixing block onto the motor with M8*40 bolt, do not tighten.
- 2、用 M8*45 的圆头螺钉穿过固定板与固定块上的螺纹孔固定锁紧。
2. Using a M8 * 45 bolt and the hang-plate to tighten the fixing block and motor.

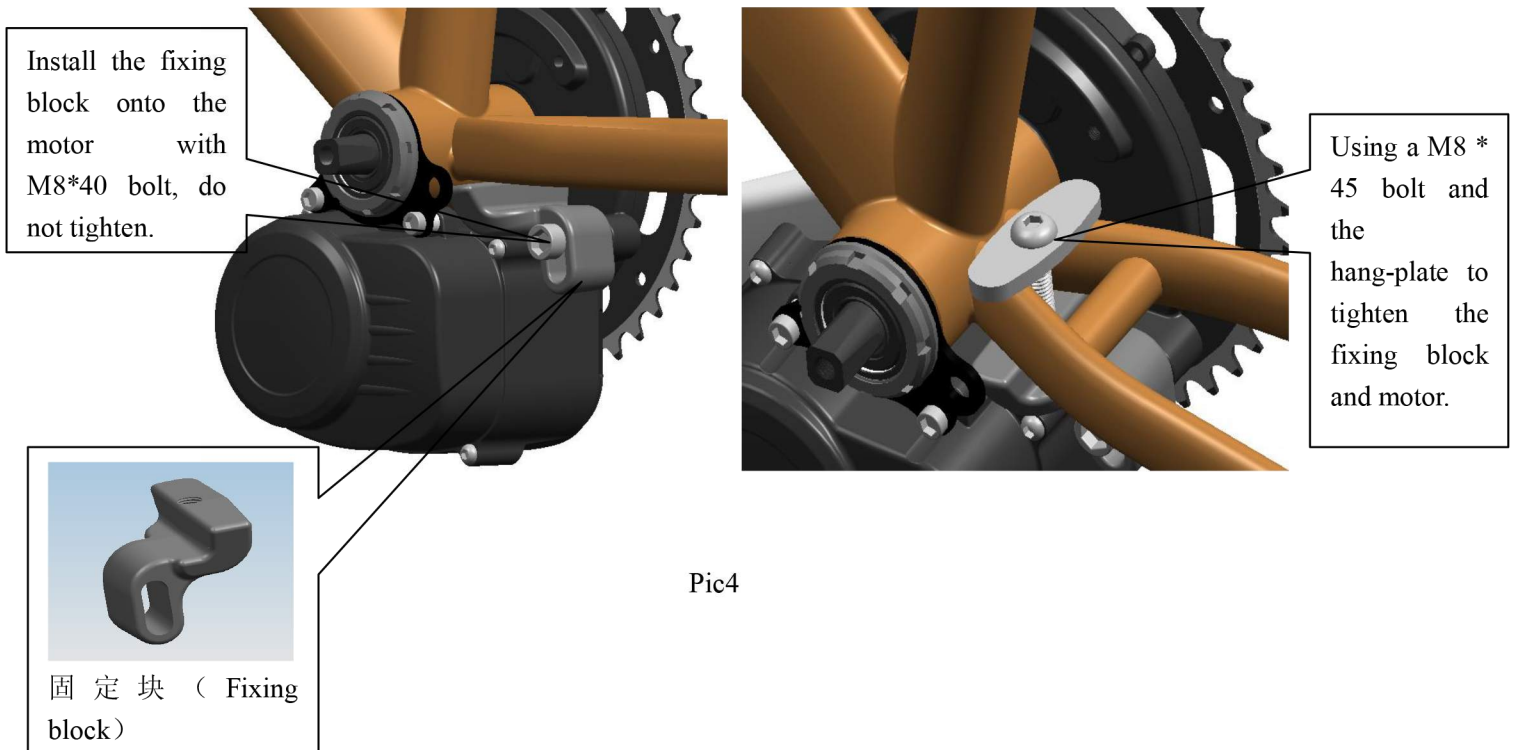

Pic4

第五步：用 $40\text{N} \cdot \text{m}$ 的力旋紧 M8*40 的螺钉（最终锁紧）。如图 5
 Step 5. Tighten the bolt with $40\text{N} \cdot \text{m}$ torque force. Please refer to Pic5.

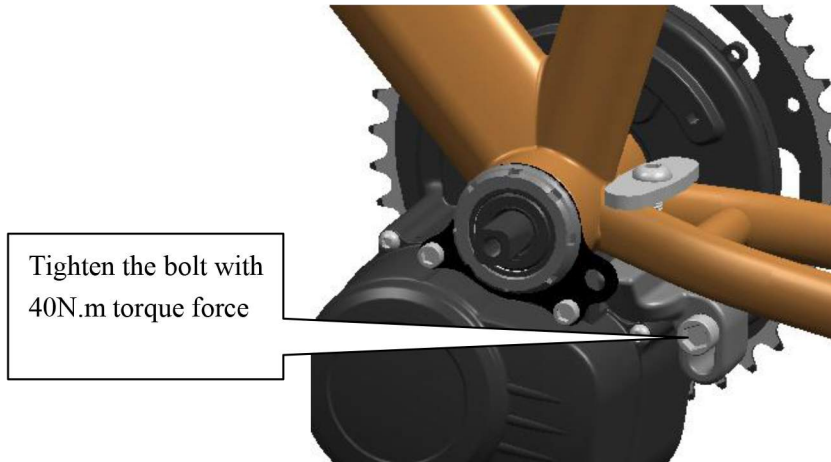

Pic5

第六步：安装曲柄。如图 6.

Step 6. Install arm-cranks.

用 M8×14 内六角螺钉安装左右曲柄，锁紧扭力为 40N·m。

Using M8×14 bolts to install the arm-cranks. The locking torque is 40N.m.

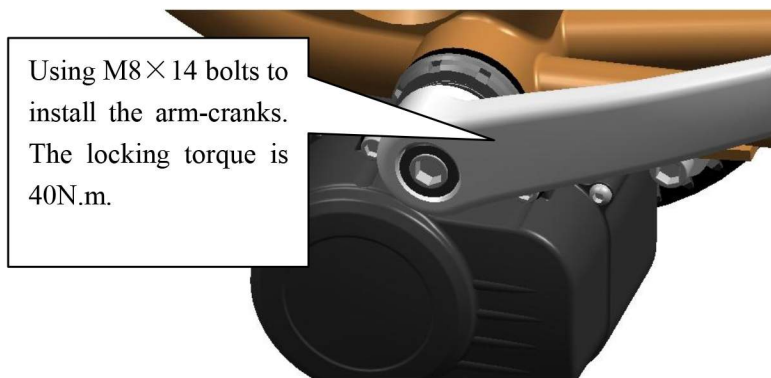

Pic6

2 仪表安装 Display Installation Process

第一步：安装仪表。如图 7.

Step 1. Install VLCD5 display. Please refer to Pic7.

用 2 个 M4×14 内六角圆柱头螺钉及 2 个 M4 的方螺母将仪表固定在图示位置处

Install the LCD display onto the handlebar using 2pcs of M4×14 bolts and 2pcs of M4 nuts

支架规格：φ 32, 内有调节圈。

The bracket is φ 32 with adjust rings for different handlebar sizes.

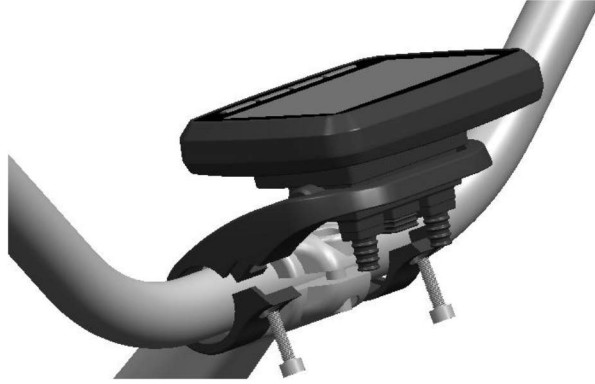

Pic7

第二步、安装左手操作开关。如图 8。

Step 2. Install left hand remote control buttons. Please refer to Pic8.

用 2 个 M2.5×10 内六角圆柱头螺钉将操作开关固定在图示位置处



Pic8

3 车速传感器安装 Detective sensor Installation

第一步：装传感器

用两根扎带将车速传感器支座固定在车架后平叉上；

Install the detective sensor onto the bike rear fork with two ribbons as shown below

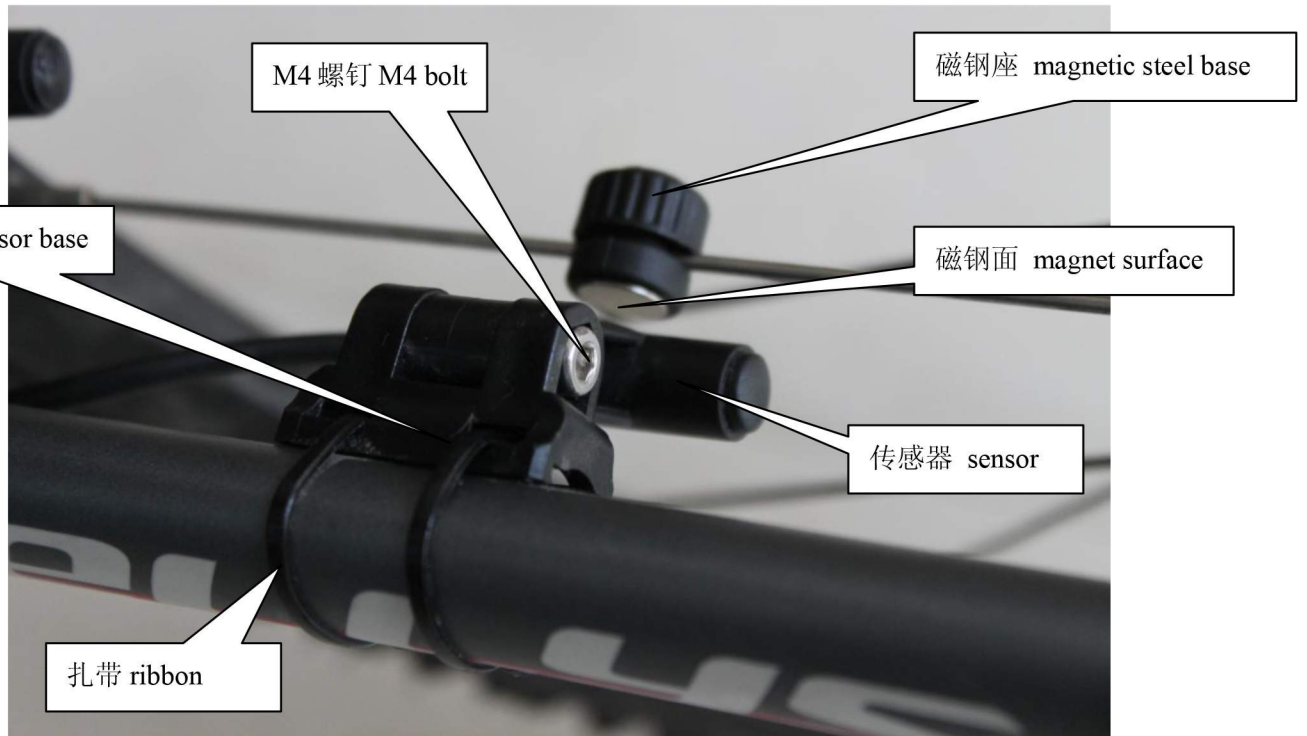

Pic9

第二步：装磁钢座 install magnet steel

将磁钢座安装在后轮辐条上，且磁钢面朝向传感器； install the magnet steel onto the rear fork, facing the detective sensor

第三步：调节磁钢面与传感器的距离 Adjust the distance between sensor and magnet steel
转动传感器使其与磁钢面的距离不大于 5mm，然后上紧 M4 螺钉。

The distance between the sensor and the magnet steel should below 5mm. Tighten the M4 bolt.

4 系统连接 System connection

第一步：将操作器与仪表的插件插好； Step one: connect the display and operation button.



第二步：将断电刹把插到仪表的底座上，本系统可以不用断电刹把； Step two: insert the brake-levers plugs into the display. The brake-levers are optional.



第三步：将仪表与中置电机的插件插好； Step three: connect the main motor and the display



第四步：将车速传感器与中置电机的插件插好； Step four: connect the main motor and the detective sensor



第五步：将中置电机的两根电源连接到电池上。 Step five: connect the motor and the battery

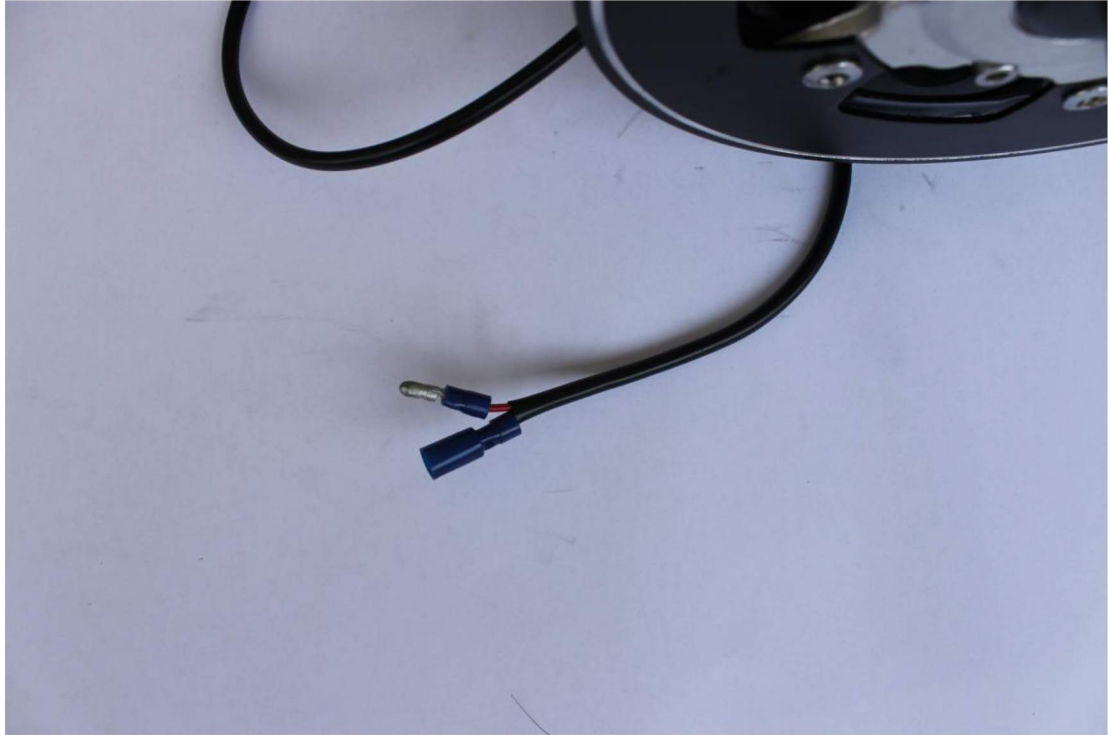

接线图

System connection

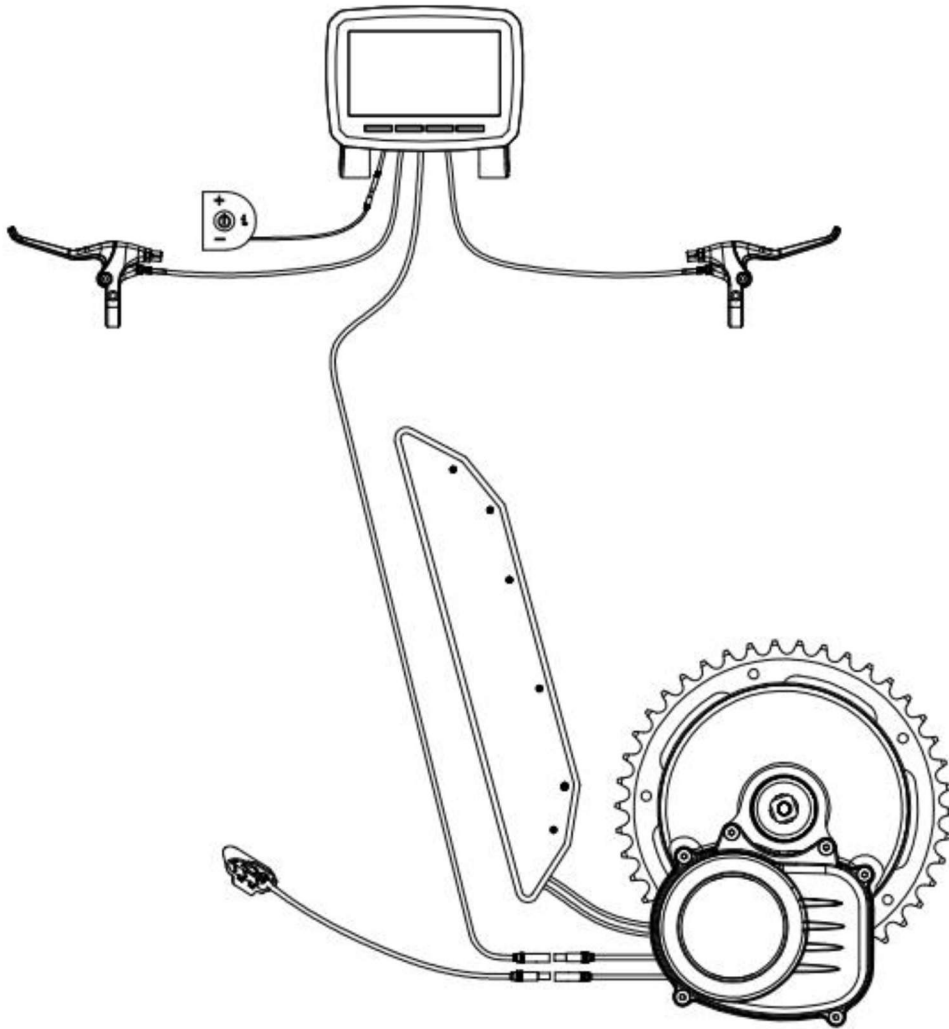

电机安装尺寸

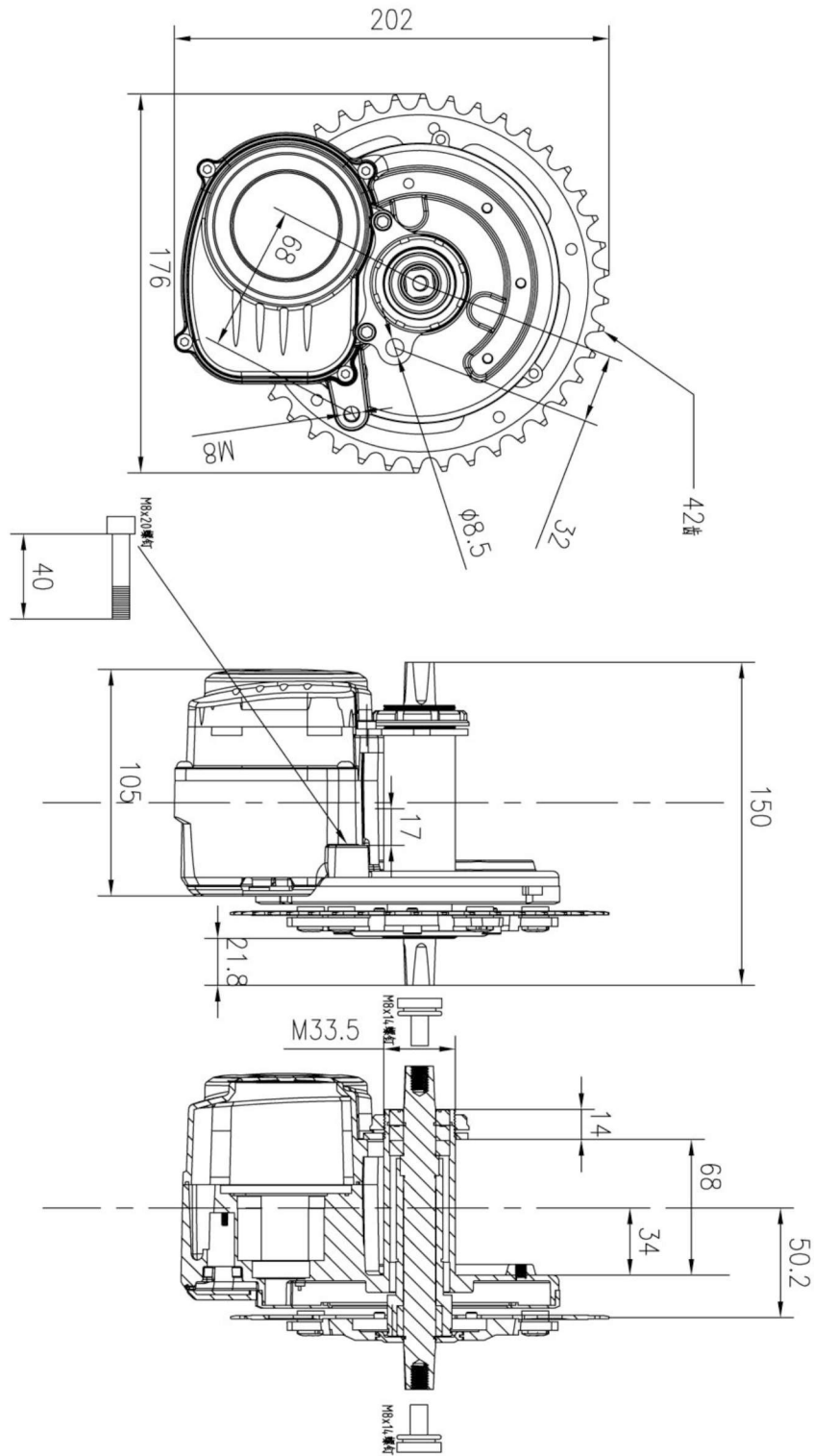

零部件清单

Parts List

- 1、中置电机 center motor 1 台
- 2、VLCD5 液晶仪表 display 1 只
- 3、VLCD5 液晶仪表支架 display bracket (φ 32) 1 付
- 4、左手操作开关 left hand operator 1 只
- 5、刹把 brake-lever 1 付(optional)
- 6、车速传感器 detective sensor 1 套
- 7、加强板 securing plate 1 片
- 8、M33.5mm 螺母 bolt 1 个
- 9、固定板 hanging plate 1 个
- 10、固定块 securing block 1 个
- 11、M8 X 45 圆头螺钉 roundhead bolt 1 个
- 12、M5X 16 内六角螺钉 Hexagon socket head bolt 2 个
- 13、Φ 5X5 铝垫片 Aluminum washer 2 个
- 14、专用安装工具 wrench 1 个
- 15、曲柄 170MM crank-arm 1 付(1 set)
- 16、VLCD 仪表操作说明书 (中英文) display manual (Chinese&English) 1 本
- 17、TSDZ2 中置电机系统装配手册 (中英文) center motor install manual 1 本。